

1 Datasheet X-TEC 15M HAND-MOUNTING-male 10-14 MM

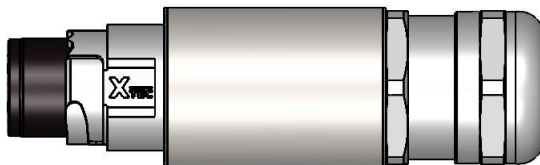

source

destination

2 Application

Connection of 3-phase consumers with 2 Signalpins

3 General component properties

3.1 Cataloguing

DESIGNATION	VALUE	UNIT
product designation of manufacturer	X-TEC 15 Accessories	
Manufacturer Article Number	1146875	
Application standards	PERFORMANCE	
UL Mark	UL Listed	
eCl@ss 9.0	27-44-03-90	
country of origin	DE	

08.11.2023-RSP	Adaptation Eclass	9.0		UL- Identification	Order no.	
26.10.2023-RSP	Adaptation Eclass	8.0		W-TEC 15M-KCS-XXX-61414-14-AS	1146875-00000	
24.08.2023-RSP	Rated current main wires *	7.0		Designation	Datasheet	
07.08.2023-RSP	New: IEC 61076-2-116	6.0		X-TEC 15M HAND-MOUNTING-male	Created	Page
Change No.	Description of changes	Index		10-14 MM	09.11.2023-RSP	1

The information contained in this data sheet was compiled with the greatest possible care.
 For correctness, completeness and topicality the liability is limited to gross negligence.
 All rights reserved to DIN 34

LQ Mechatronik-Systeme GmbH
 Carl-Benz-Str. 6 D-74354 Besigheim
 Tel. +49 (0) 71 43 / 968-0 - info@de.lq-group.com

3.2 Electrical properties

DESIGNATION	VALUE	UNIT
rated current	16	A
Rated current auxiliary wires	10	A
rated voltage	600	V AC
Rated voltage auxiliary wires	250	V AC / DC
rated impulse voltage	6	kV
shielded	Yes	
protective conductor connection	according to VDE 0627	
Overvoltage category according to DIN EN 60664-1	3	
Plugging under voltage according to DIN EN 61984	No	
degree of contamination	3	
protective conductors	yes (PE) 1,2mm leading	
neutral conductor	No	
Degree of protection by encapsulation according to IEC 60529	No	
Reference to standard	DIN EN 61984 / IEC 61076-2-116	

If the plug connection is disconnected for an indefinite period of time from a exposed to industrial atmospheres, the contact chamber is equipped with a cover cap to protect against pollution.

*To determine max. load currents, deratings for used connection conductor cross-sections as well as reduction factors for conductors, cables and lines in the electrical equipment of machines according to DIN EN 60204-1 must be taken into account.

3.3 Weights

DESIGNATION	VALUE	UNIT
Connector Source	99	g

3.4 Approval

DESIGNATION	VALUE	UNIT
UL.CCN **	PVVA.E486020	
CSA.CCN **	PVVA7.E486020	
CCC	No	
GOST-R	No	
CE Nomenclature	X-TEC 15M-KXX-XXX-XXXXX-KK-AS	

3.4.1 Approvals Supplements

** Suitable For Use On a Circuit Capable Of Delivering Not More Than 5,000 rms Symmetrical Amperes, 600V Maximum.
When Protected by Time Delay (See Table Below) Class Fuses:

08.11.2023-RSP	Adaptation Eclass	9.0		UL- Identification	Order no.	
26.10.2023-RSP	Adaptation Eclass	8.0		W-TEC 15M-KCS-XXX-61414-14-AS	1146875-00000	
24.08.2023-RSP	Rated current main wires *	7.0		Designation	Datasheet	
07.08.2023-RSP	New: IEC 61076-2-116	6.0		X-TEC 15M HAND-MOUNTING-male	Created	Page
Change No.	Description of changes	Index		10-14 MM	09.11.2023-RSP	2

The information contained in this data sheet was compiled with the greatest possible care.
For correctness, completeness and topicality the liability is limited to gross negligence.
All rights reserved to DIN 34

LQ Mechatronik-Systeme GmbH
Carl-Benz-Str. 6 D-74354 Besigheim
Tel. +49 (0) 71 43 / 968-0 - info@de.lq-group.com

Cat. No(s).	Time Delay (TD) /Non-time delay (NTD)	Fuse Class	Fuse Current Rating (A)	SCCR (kA)	Voltage V AC
All rated 13 A	TD	RK5	25	5	600
	TD	J	60	50	600
	TD	CC	30	50	600
All rated 16 A	TD	RK5	35	5	600
	TD	J	60	50	600
	TD	CC	30	50	600

Suitable For Use On A Circuit Capable Of Delivering Not More Than 50kA rms Symmetrical Amperes, 480 Vac Maximum, When Protcted By A Circuit Breaker Rated Not More Than 16A, Having An Interrupting Rating Not Less Than 50kA rms Symmetrical Amperes, 480Vac Maximum.

Circuit Breakers:

Cat. No(s).	Model/Type	Manufacturer / UL File	Current Rating (A)	SCCR (kA)	Voltage V AC
All	Any	Any / Any	16	50	480Y/277 Vac

3.4.2 Enclosure Type Rating

X - T E C 1 5 - - - X X X ...

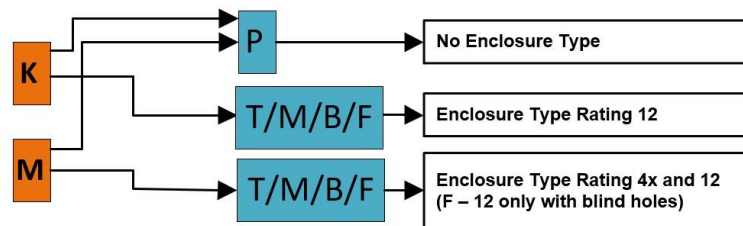

X - T E C 1 5 - X X X - - - ...

3.5 Thermal properties

DESIGNATION	VALUE	UNIT
Max. operating temperature	70	°C
Fixed temperature range (LLT-ULT)	-35 ... +70	°C

08.11.2023-RSP	Adaptation Eclass	9.0		UL- Identification	Order no.	
26.10.2023-RSP	Adaptation Eclass	8.0		W-TEC 15M-KCS-XXX-61414-14-AS	1146875-00000	
24.08.2023-RSP	Rated current main wires *	7.0		Designation	Datasheet	
07.08.2023-RSP	New: IEC 61076-2-116	6.0		X-TEC 15M HAND-MOUNTING-male 10-14 MM	Created	Page
Change No.	Description of changes	Index		09.11.2023-RSP	3	

The information contained in this data sheet was compiled with the greatest possible care. For correctness, completeness and topicality the liability is limited to gross negligence. All rights reserved to DIN 34

LQ Mechatronik-Systeme GmbH
Carl-Benz-Str. 6 D-74354 Besigheim
Tel. +49 (0) 71 43 / 968-0 - info@de.lq-group.com

3.6 UL Ratings

DESIGNATION	VALUE	UNIT
Reference to UL standard	2237	
max. connectable conductor size (AWG/KCMIL)	16-14	AWG
Auxiliary wires Wire gauge	16-14	AWG
Enclosure Type Rating	4X, 12	
flame-resistant (in accordance with UL94)	HB	

3.7 Other features

DESIGNATION	VALUE	UNIT
RoHS compliant	2011/65/EU	
REACH SVHC substances	-	
halogen-free	Yes	
oil and grease resistant	Yes	
flame-resistant	Yes	

The material of the housing-encapsulation is plastic and has a good resistance to chemicals and oil. If aggressive media are used, the material resistance must be checked in relation to the application. Further details on request.

08.11.2023-RSP	Adaptation Eclass	9.0		UL- Identification	Order no.	
26.10.2023-RSP	Adaptation Eclass	8.0		W-TEC 15M-KCS-XXX-61414-14-AS	1146875-00000	
24.08.2023-RSP	Rated current main wires *	7.0		Designation	Datasheet	
07.08.2023-RSP	New: IEC 61076-2-116	6.0		X-TEC 15M HAND-MOUNTING-male	Created	Page
Change No.	Description of changes	Index		10-14 MM	09.11.2023-RSP	4

The information contained in this data sheet was compiled with the greatest possible care. For correctness, completeness and topicality the liability is limited to gross negligence. All rights reserved to DIN 34

LQ Mechatronik-Systeme GmbH
 Carl-Benz-Str. 6 D-74354 Besigheim
 Tel. +49 (0) 71 43 / 968-0 - info@de.lq-group.com

4 General structure

4.1 Allocation plan

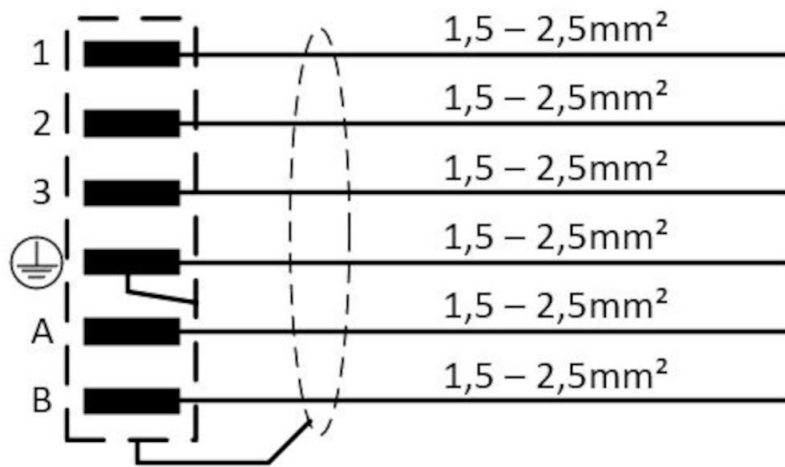

08.11.2023-RSP	Adaptation Eclass	9.0		UL- Identification	Order no.	
26.10.2023-RSP	Adaptation Eclass	8.0		W-TEC 15M-KCS-XXX-61414-14-AS	1146875-00000	
24.08.2023-RSP	Rated current main wires *	7.0		Designation	Datasheet	
07.08.2023-RSP	New: IEC 61076-2-116	6.0		X-TEC 15M HAND-MOUNTING-male	Created	Page
Change No.	Description of changes	Index		10-14 MM	09.11.2023-RSP	5

The information contained in this data sheet was compiled with the greatest possible care.
For correctness, completeness and topicality the liability is limited to gross negligence.
All rights reserved to DIN 34

LQ Mechatronik-Systeme GmbH
Carl-Benz-Str. 6 D-74354 Besigheim
Tel. +49 (0) 71 43 / 968-0 - info@de.lq-group.com

5 Construction Source

5.1 Pole diagram Source

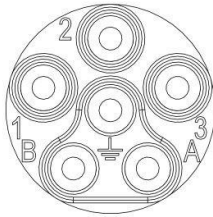

5.2 Construction Source

DESIGNATION	VALUE	UNIT
Size of construction	X-TEC 15	
Type of interlock	Quick release fastener	
Execution	free plug-in pin	
Number of poles	6	
Construction form of the plug connector	straight	
clamping area	10 - 14	mm
Material Seals	NBR, FPM	
production type	mounted	
material of housing	NiRo Steel, zinc, brass, nickel-plated	
Material Insulating body	PA 6.6	
Conductor connection method	Crimp connection	
Material Contacts	Copper alloy, hard silver plated	
contact resistance	<3	mOhm
Mechanical life Contacts	500	mating cycles
connectable wires	fine to finely stranded	
Degree of protection (IP), mounted	IP65	

08.11.2023-RSP	Adaptation Eclass	9.0		UL- Identification	Order no.	
26.10.2023-RSP	Adaptation Eclass	8.0		W-TEC 15M-KCS-XXX-61414-14-AS	1146875-00000	
24.08.2023-RSP	Rated current main wires *	7.0		Designation	Datasheet	
07.08.2023-RSP	New: IEC 61076-2-116	6.0		X-TEC 15M HAND-MOUNTING-male	Created	Page
Change No.	Description of changes	Index		10-14 MM	09.11.2023-RSP	6

The information contained in this data sheet was compiled with the greatest possible care.
For correctness, completeness and topicality the liability is limited to gross negligence.
All rights reserved to DIN 34

LQ Mechatronik-Systeme GmbH
Carl-Benz-Str. 6 D-74354 Besigheim
Tel. +49 (0) 71 43 / 968-0 - info@de.lq-group.com

5.3 Schematic diagram Source

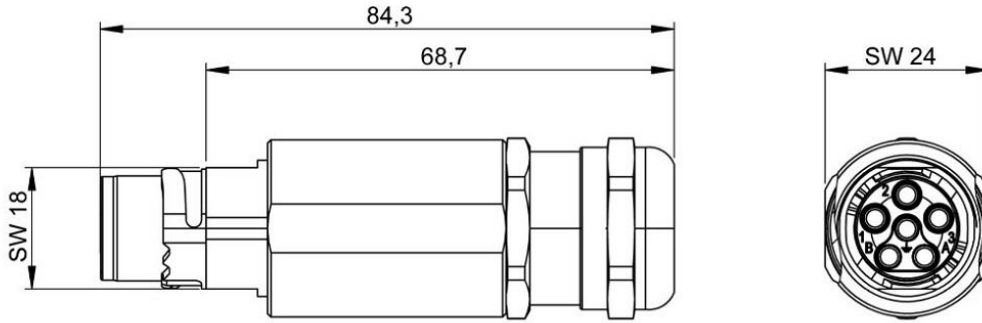

08.11.2023-RSP	Adaptation Eclass	9.0		UL- Identification	Order no.	
26.10.2023-RSP	Adaptation Eclass	8.0		W-TEC 15M-KCS-XXX-61414-14-AS	1146875-00000	
24.08.2023-RSP	Rated current main wires *	7.0		Designation	Datasheet	
07.08.2023-RSP	New: IEC 61076-2-116	6.0		X-TEC 15M HAND-MOUNTING-male	Created	Page
Change No.	Description of changes	Index		10-14 MM	09.11.2023-RSP	7

The information contained in this data sheet was compiled with the greatest possible care.
 For correctness, completeness and topicality the liability is limited to gross negligence.
 All rights reserved to DIN 34

LQ Mechatronik-Systeme GmbH
 Carl-Benz-Str. 6 D-74354 Besigheim
 Tel. +49 (0) 71 43 / 968-0 - info@de.lq-group.com

6 Assembly instructions

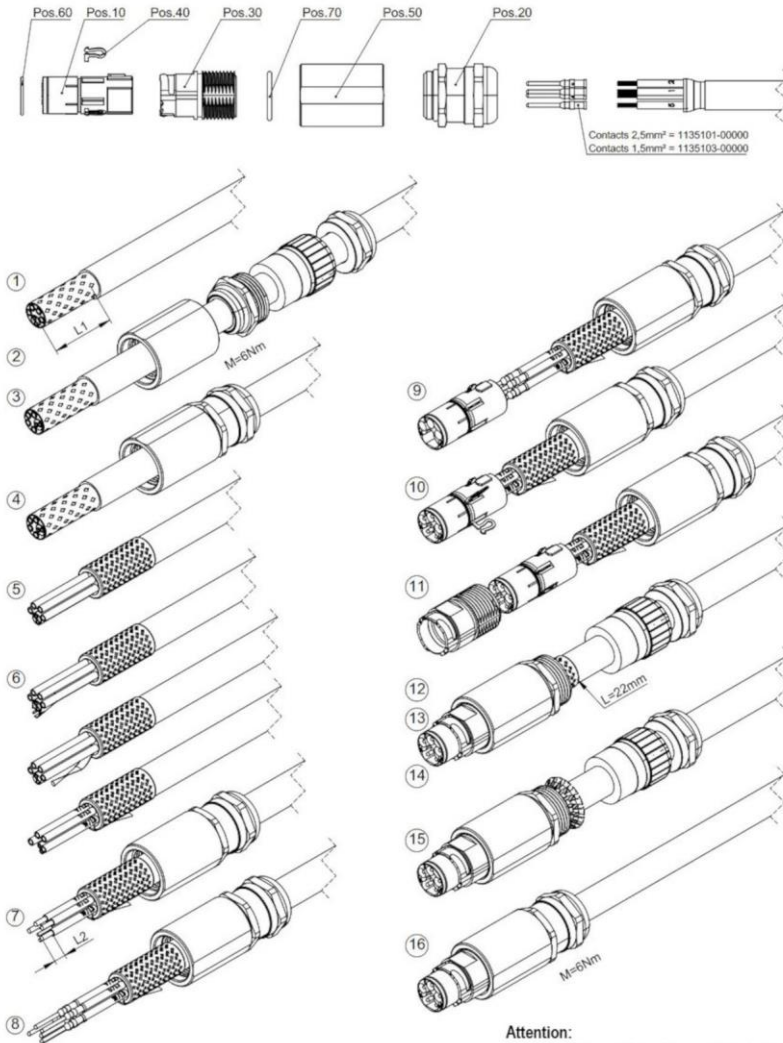

Attention:
In case of dismantling the contacts (particularly PE)
-> disassemble positions 10; 30 & 40 in advance!

- !Please ensure that the O-rings are fitted in the correct position!
- ① Remove cable sheath $L1 = 50 \pm 1\text{mm}$ (for cable: $4 \times 2,5$ & $2 \times 1,5$)
 - ② Remove taped wrapping-, core and filler elements
 - ③ Fit Pos.50 and Pos.20 together
 - ④ Screw Pos.20 into Pos.50
 - ⑤ Turn the external shield braiding upside down towards the rear. (Do not untwist the shield)
 - ⑥ Untwist the internal shield and put it along the external shield to the rear.
 - ⑦ Shorten the strand ends accordingly and strip them $L2 = 8\text{mm}$ (for $1,5\text{mm}^2$) and 6mm (for $2,5\text{mm}^2$) / (PE 2mm longer than the other conductors)
 - ⑧ Crimp contacts -> crimping tool LQ order no.: 1148172-00000
 - ⑨ Guide contacts into Pos.10 and engage (Note contact assignment/numbering)
 - ⑩ Insert Pos.40 (Note alignment of PE springs)
 - ⑪ Lock Pos.30 to Pos.10 (Note alignment)
 - ⑫ Screw Pos.50 to Pos.30 (Screw Pos.50 to the stop)
 - ⑬ Screw intermediate piece (part of Pos.20) individually into Pos.50
 - ⑭ Push clamping insert forwards (part of Pos.20) and pull on shield braiding
 - ⑮ Untwist shield and cut to length of 22mm
-> Then insert the clamping insert in the intermediate piece
 - ⑯ Screw all components together -> Note sequence and torques

Cord - R/C (AVLV2) and CAN, 14 or 16 AWG with 4 or 6 stranded Copper conductors crimped to Contacts/Pins (Item 3), rated minimum 80 deg. C, 600 V, as outlined in table under Item 1 above. Jackets and AWM styles as in the table below:

Cat. No.	Jacket material	AWM Style
X-TEC 15M ...-T...	TPU	21223 (+)

Note:
(+) any other AWM style allowed for use as external interconnection with jacket material made of TPU or PUR rated minimum 80 deg. C, 600 V can be used;

The following cord diameters apply for all Cat. No. using suffix "A" in position IV or VII (see Nomenclature for details)

Cat. No.	clamping range/cord diameters	measuring unit
X-TEC 15M ...-12T	8 - 11,6	mm
X-TEC 15M ...-14T	10,1 - 13,9	mm

08.11.2023-RSP	Adaptation Eclass	9.0		UL- Identification	Order no.	
26.10.2023-RSP	Adaptation Eclass	8.0		W-TEC 15M-KCS-XXX-61414-14-AS	1146875-00000	
24.08.2023-RSP	Rated current main wires *	7.0		Designation	Datasheet	
07.08.2023-RSP	New: IEC 61076-2-116	6.0		X-TEC 15M HAND-MOUNTING-male 10-14 MM	Created	Page
Change No.	Description of changes	Index			09.11.2023-RSP	8

The information contained in this data sheet was compiled with the greatest possible care. For correctness, completeness and topicality the liability is limited to gross negligence. All rights reserved to DIN 34

LQ Mechatronik-Systeme GmbH
Carl-Benz-Str. 6 D-74354 Besigheim
Tel. +49 (0) 71 43 / 968-0 - info@de.lq-group.com

7 Derating

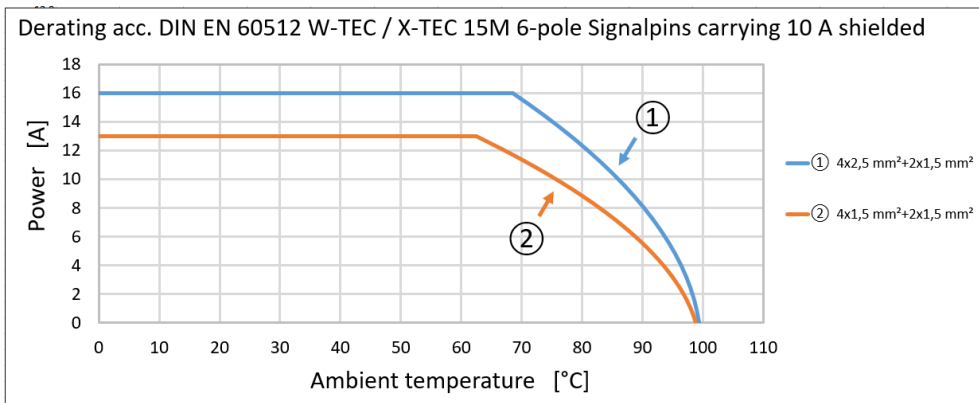
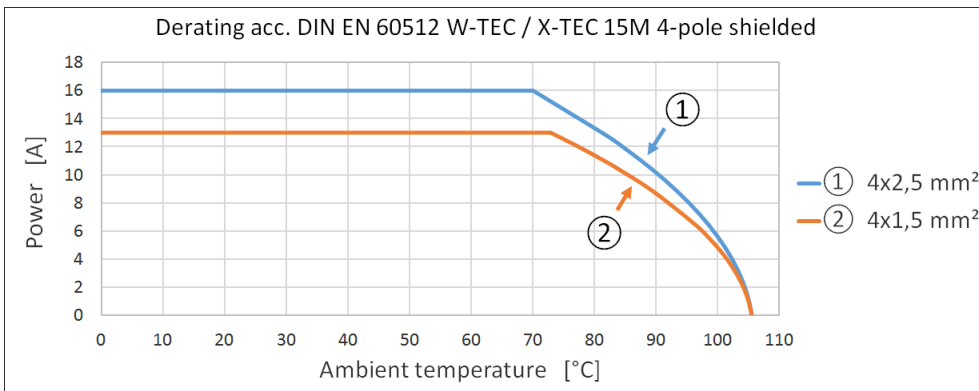
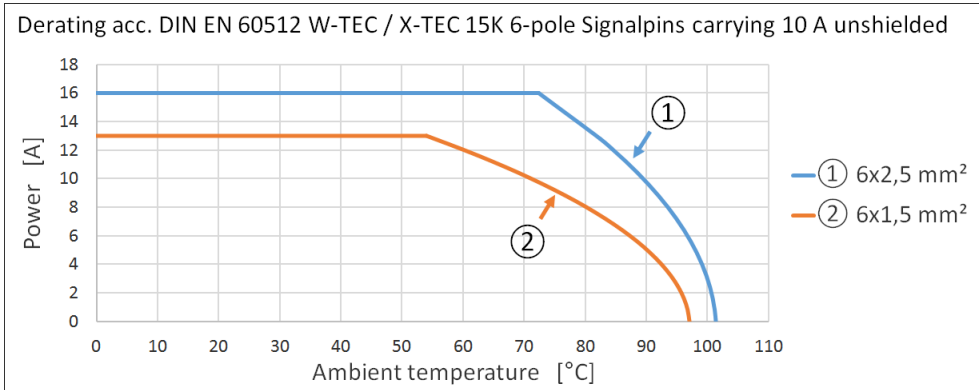
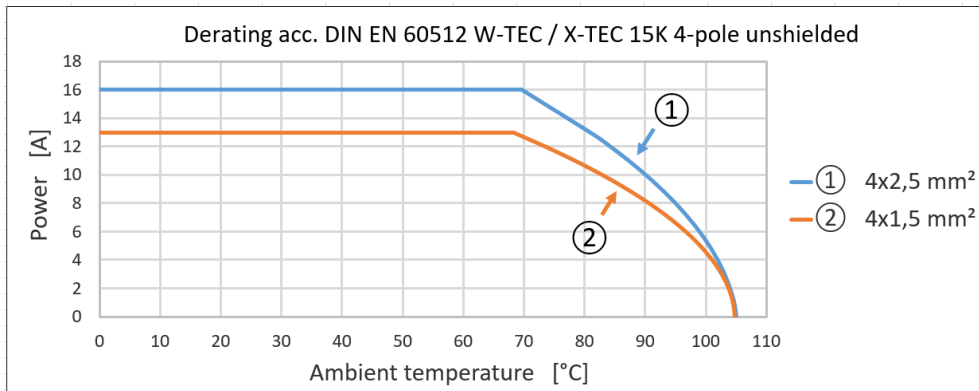

08.11.2023-RSP	Adaptation Eclass	9.0		UL- Identification	Order no.	
26.10.2023-RSP	Adaptation Eclass	8.0		W-TEC 15M-KCS-XXX-61414-14-AS	1146875-00000	
24.08.2023-RSP	Rated current main wires *	7.0		Designation	Datasheet	
07.08.2023-RSP	New: IEC 61076-2-116	6.0		X-TEC 15M HAND-MOUNTING-male	Created	Page
Change No.	Description of changes	Index		10-14 MM	09.11.2023-RSP	9

The information contained in this data sheet was compiled with the greatest possible care. For correctness, completeness and topicality the liability is limited to gross negligence. All rights reserved to DIN 34

LQ Mechatronik-Systeme GmbH
 Carl-Benz-Str. 6 D-74354 Besigheim
 Tel. +49 (0) 71 43 / 968-0 - info@de.lq-group.com

8 Appendix Nomenclature

X - T E C 1 5 K - P C S - X X X - 6 1 4 1 4 - X X - W X -

Family designation

- X-TEC
 - Panel mounted connectors
 - Power distribution box

Connector Size

- 15
- 12

Connector type

- K – plastic connector
- M – metal connector

Male/Female contactor type

- T – threaded body
- F – rectangular flange
- P – threaded body including plastic coupling nut
- M – threaded body including metallic coupling nut
- B – threaded body including reducing bush
- C – T-Splitter (one inlet)
- D – 4-way splitter, with top-gated outlets (four outlets)
- E – 4-way splitter, with side-gated outlets (four outlets)
- X – No male/female connector
- K – threaded body including screwed coupling and cable gland (field-assembled construction)

Male/Female contact type

- C – crimp
- X – No male/female connector
- T – No Male/female connector, additional terminal/ferrule crimped to wire ends, resistance welded wire ends, single wire lengths may be varying (Female Panel mounted)

Male/Female contact plating

- S – Silver
- X – No male/female connector

Cable Screen

- X – stranded copper conductors not shielded

Cable Type

- W – stranded copper conductors

Cable gland size

- XX – no cable gland

Signal contact terminal cross-section

- 14 – AWG 14
- 16 – AWG 16
- XX – no signal contacts

Power contact terminal cross-section

- 14 – AWG 14
- 16 – AWG 16

Number of poles

- 4 – 4 poles
- 6 – 6 poles

1 1 2 4 2 7 8 - 0 0 0 1 4

internal description, where xxxxxxx can be 7 digit alphanumeric

internal description, where xxxxxxx can be 7 digit alphanumeric

- Ferrules with insulating collar
- Uninsulated ferrules
- Terminal Connectors,
- **Uninsulated Terminal Connectors,**
- dust caps

and additional features which may be

- welded/compacted stranded wire ends
- additional stripping of wire
- additional stripping of cord isolation
- length difference between power, ground and signal wires

five digit number describing cable length in cm

08.11.2023-RSP	Adaptation Eclass	9.0		UL- Identification	Order no.	
26.10.2023-RSP	Adaptation Eclass	8.0		W-TEC 15M-KCS-XXX-61414-14-AS	1146875-00000	
24.08.2023-RSP	Rated current main wires *	7.0		Designation	Datasheet	
07.08.2023-RSP	New: IEC 61076-2-116	6.0		X-TEC 15M HAND-MOUNTING-male	Created	Page
Change No.	Description of changes	Index		10-14 MM	09.11.2023-RSP	10

The information contained in this data sheet was compiled with the greatest possible care. For correctness, completeness and topicality the liability is limited to gross negligence. All rights reserved to DIN 34

LQ Mechatronik-Systeme GmbH
Carl-Benz-Str. 6 D-74354 Besigheim
Tel. +49 (0) 71 43 / 968-0 - info@de.lq-group.com